

# AMW 9615/IX UK

12NC: 858761501900

GTIN (EAN) code: 8003437395741

Whirlpool

SENSING THE DIFFERENCE

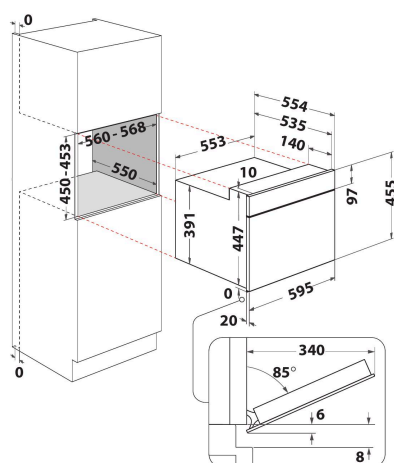

- 6TH Sense technology
- 6TH Sense CRISP Function with CRISP Plate
- Crisp Function
- Cavity 40 L
- Jet Start: rapid food reheating
- Jet Defrost: fast reheating
- Forced Air
- Keep warm
- Turbo Grill
- Bread Defrost function
- 900 W microwave
- Protruding handle
- 36 cm turntable
- Frontal ventilation
- Drop down opening
- Crisp plate and handle
- Crisp Function with Crisp Plate

## Whirlpool built in microwave oven: stainless steel color - AMW 9615/IX UK

This Whirlpool built in Microwave Oven features: stainless steel color. Outstanding cavity size. Combination technology, providing the cooking flexibility of traditional ovens. Exclusive 6th SENSE technology, that automatically sets the time, temperature and energy consumption, during cooking. Crisp function, for unbeatably crisp quiches, pizzas and pies.

### Crisp

Unbeatable crispness. This Whirlpool Microwave's Crisp function and dedicated pan ensures you can cook the crispiest pizza, pie or quiche, anytime.

### Dual Crisp

Enjoy an unbeatable crispness outside and a delicious tenderness inside, with DualCrisp. An exclusive technology by Whirlpool. Two microwave emission points to completely enfold food and evenly cook it also from the bottom.

### JetDefrost

Fast defrosting. Use the unique JetDefrost 3D system to defrost food effectively and with ease in your microwave oven.

### Jet Start

Outstanding reheating speed. The JetStart function boosts the heat inside the oven to the maximum for 30 seconds, providing the ideal temperature to reheat food with high water content such as clear soups or beverages.

### 6TH SENSE technology

Confident cooking. With 6TH SENSE technology, your microwave automatically sets the time, temperature and energy levels during the cooking process.

### 6TH SENSE technology Absolute

Always reach outstanding results. Thanks to the intuitive 6thSense central knob, you can easily set your microwave in few simple steps. Select one of the 6thSense 15 pre-set cooking cycles and your microwave automatically adapts time and power level needed.

### 40 litres capacity

More room for your cooking creations. This Whirlpool Microwave offers an outstanding 40-litre capacity, ensuring you'll never run out of space to explore new recipes.

### Antifinger

Easy to clean. Anti-fingerprint treatment ensures fingerprints, dust and scratches are easily removed. Cleaning is easier than ever.

# AMW 9615/IX UK

12NC: 858761501900

GTIN (EAN) code: 8003437395741

**Whirlpool**

SENSING THE DIFFERENCE

## MAIN FEATURES

Product group	Microwave
Commercial code	AMW 9615/IX UK
Main colour of product	Stainless steel
Type of micro-wave oven	MW-Combi
Construction type	Built-in
Type of control	Electronic
Type of control settings	LCD
Additional cooking method Grill	Yes
Crisp	Yes
Steam	No
Additional cooking method Fan cooking	Yes
Clock	Yes
Automatic programmes	Yes
Height of the product	455
Width of the product	595
Depth of the product	560
Minimum niche height	450
Minimum niche width	556
Niche depth	550
Net weight (kg)	30.8
Cavity capacity (l)	40
Turntable	Yes
Turntable diameter (mm)	360
Integrated Cleaning system	No

## TECHNICAL FEATURES

Current (A)	16
Voltage (V)	230
Frequency (Hz)	50
Length of Electrical Supply Cord (cm)	135
Plug type	UK
Timer	No
Grill power (W)	1600
Type of grill	Heating element
Cavity material	Stainless steel
Interior light	Yes
Additional cooking method Grill	Yes
Position of interior lights of the cavity	Ceiling
Maximum Air flow -	0
Minimum air flow -	0
Sound power at max. speed (2010/30/EU) -	0
Sound power at min. speed (2010/30/EU) -	0

## PERFORMANCES

6th Sense / Dynamic Intelligence	6th Sense
Number of power levels	8
Maximum micro-wave power (W)	900
Bread defrost	Yes
Jet defrost	Yes
Jet start	Yes
Energy efficiency class - NEW (2010/30/EU) -	-