

MBNA900XN

12NC: 859991659500

GTIN (EAN) code: 8003437396861

Whirlpool

SENSING THE DIFFERENCE

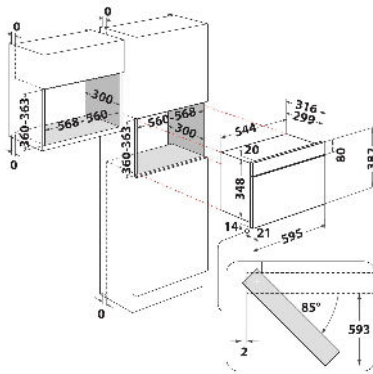

MAIN FEATURES

Product group	Mikrovalna pečnica
Commercial code	MBNA900XN
Main colour of product	Stainless steel
Type of micro-wave oven	MW only
Construction type	Ugradbeni
Type of control	Electronic
Type of control settings	LED
Additional cooking method Grill	Ne
Funkcija Crisp	Ne
Steam	Ne
Additional cooking method Fan cooking	Ne
Clock	Yes
Automatic programmes	Ne
Height of the product	382
Width of the product	595
Depth of the product	320
Minimum niche height	360
Minimum niche width	556
Niche depth	300
Net weight (kg)	19.5
Ljubičasta sa bisernim odsjajem	22
Turntable	Yes
Turntable diameter (mm)	250
Integrated Cleaning system	Ne

TECHNICAL FEATURES

Current (A)	10
Voltage (V)	220-240
Frequency (Hz)	50
Length of Electrical Supply Cord (cm)	135
Plug type	Ne
Timer	Yes
Grill power (W)	0
Type of grill	-
Funkcija Crisp	Painted
Interior light	Yes
Additional cooking method Grill	Ne
Position of interior lights of the cavity	Right side

ENERGY LABEL

6th Sense / Dynamic Intelligence	Ne
Number of power levels	4
Maximum micro-wave power (W)	750
Funkcija Bread defrost	Ne
Funkcija Jet defrost	Yes
Funkcija Jet Start	Yes