

W11 OM1 4MS2 H

12NC: 859991549450

GTIN (EAN) code: 8003437834790

Whirlpool

SENSING THE DIFFERENCE

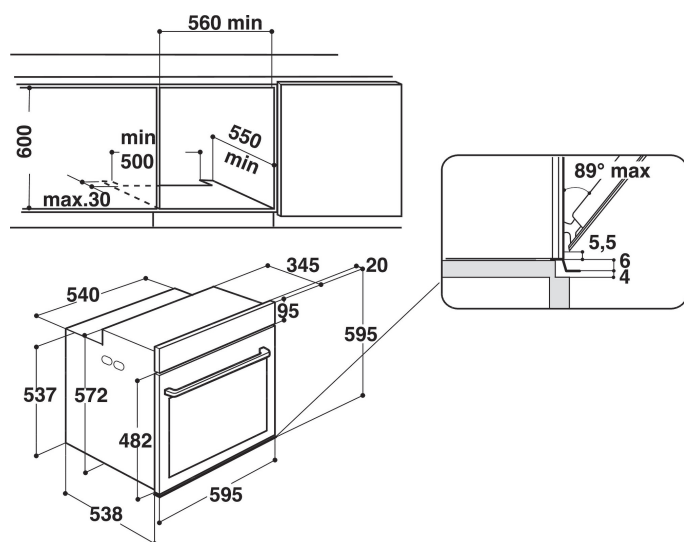

- 6TH Sense technology
- 6thSense Live
- Up to 100 6th Sense Cooking Combinations
- SmartClean
- Energy class A+
- Cavity 73 L
- Cook4
- Ready2Cook
- Defrost function
- Forced Air Fan Cooking
- Turbo Fan
- Grill
- Easy Clean Enamel Interior
- Turbo grill function
- Maxi cooking
- Pastry function
- Pizza/Bread function

Whirlpool built in electric oven: self cleaning - W11 OM1 4MS2 H

This Whirlpool built in Oven features: starClean technology, providing an eco-friendly self cleaning cycle that ensures ideal cleaning results in just 35 minutes, at the touch of a button. Advanced electric technology allowing you to cook dishes saving energy. Halogen lamp allowing a more energy-efficient performance. Exclusive 6th SENSE technology, that allows you to pick among a variety of pre-programmed recipes, and your oven will automatically adjust cooking, temperature and time settings, to ensure perfect results. Innovative Cook4 function, that allows you to cook up to four separate dishes at the same time, without the risk of aromas mixing.



6th Sense W11

No more guesswork. Simply pick your recipes, and let 6th SENSE cook them to perfection, every time. Up to 100 cooking combinations organized to fit your lifestyle and diet, for a full assisted cooking experience.



Ready2cook

No pre-heating required. The Ready2Cook function uses a powerful convection system to quickly reach the right temperature, and completely eliminate the need for pre-heating.



Cook4

The Cook4 function provides a unique level of flexibility that enables consumers to cook up to four dishes at the same time without mixing any of the flavours or aromas.



6th Sense Live App

6TH SENSE technology automatically adjusts time, temperature, and humidity settings to ensure perfect results time after time. With the 6TH SENSE sensors and an exciting choice of exclusive options, consumers can whip up the perfect meal while enjoying an unparalleled intuitive experience.



Electronic control

Electronic temperature control.



My Smart Display

An intuitive, uncluttered, and easy-to-read interface that assists consumers to help them to become better, more inspired cooks. By simply choosing one of the many Cooking Combinations, MySmartDisplay guides consumers through each and every step from start to lip-smacking finish in real time.

W11I OM1 4MS2 H

12NC: 859991549450

GTIN (EAN) code: 8003437834790

Whirlpool

SENSING THE DIFFERENCE

MAIN FEATURES

Product group	Oven
Commercial code	W11I OM1 4MS2 H
Main colour of product	Dark grey
Construction type	Built-in
Type of control	Electronic
Type of control settings	-
Are any hobs controls integrated?	No
Which kind of hobs can be controlled?	-
Automatic programmes	Yes
Current (A)	16
Voltage (V)	220-240
Frequency (Hz)	50/60
Length of Electrical Supply Cord (cm)	90
Plug type	No
Depth with open door 90 degree (mm)	-
Height of the product	595
Width of the product	595
Depth of the product	564
Minimum niche height	0
Minimum niche width	0
Niche depth	0
Net weight (kg)	40.5
Usable volume (of cavity)	73
Integrated Cleaning system	Hydrolytic
Grids of the cavity	2
Trays	2

TECHNICAL FEATURES

Timer	-
Time control	Electronic
Time-setting options	Start and Stop
Safety device	-
Interior light	Yes
Number of interior lights of the cavity	2
Position of interior lights of the cavity	Right side
Oven guides of the cavity	Grids
Probe of the cavity	Yes

PERFORMANCES

Energy input	Electric
Type of energy of the cavity	Electricity
Energy efficiency class - NEW (2010/30/EU)	A+
Energy consumption per cycle conventional - NEW (2010/30/EU)	0.91
Energy consumption per cycle forced air convection - NEW (2010/30/EU)	0.7



ENERG Y UA
енергия · ενεργεια IE IA

WHIRLPOOL
W11I OM1 4MS2 H



A+



73 l



0.91 kWh/cycle*



0.7 kWh/cycle*

* циска - cyklus - portion - zykus - nopolymassa - ciclo - tsükkel - ohjelma - ciklus - cikls - ciklu - cycles - cykl - ciclu - program - cykel

65/2014