

# W11 MW161

12NC: 859991539470

GTIN (EAN) code: 8003437395918

Whirlpool

SENSING THE DIFFERENCE

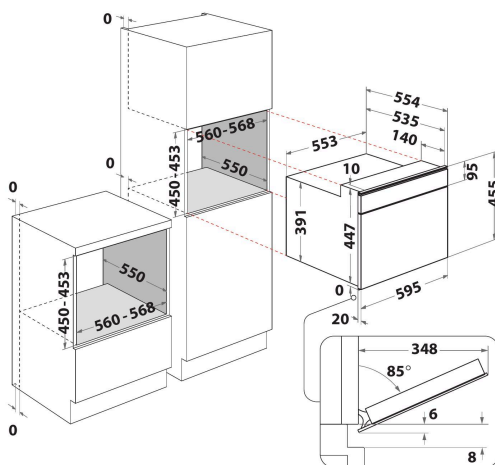

- 6thSense Live
- 6TH Sense technology
- 6TH Sense CRISP Function with CRISP Plate
- 6th Sense Reheat
- 6th Sense Defrost
- Crisp Function
- Cavity 40 L
- Jet Start: rapid food reheating
- Jet Defrost: fast reheating
- Forced Air
- Keep warm
- Steam function
- Turbo Grill
- Rising Function
- Steam&Boil (Built-in)
- CrispFry
- Bread Defrost function

## Whirlpool built in microwave oven - W11 MW161

This Whirlpool built in Microwave Oven features: outstanding cavity size. Combination technology, providing the cooking flexibility of traditional ovens. Exclusive 6th SENSE technology, that automatically sets the time, temperature and energy consumption, during cooking. Crisp function, for unbeatably crisp quiches, pizzas and pies. Jet Defrost function for exceptionally fast and even defrosting.



### Dual Crisp

Enjoy an unbeatable crispness outside and a delicious tenderness inside, with DualCrisp. An exclusive technology by Whirlpool. Two microwave emission points to completely enfold food and evenly cook it also from the bottom.



### JetDefrost

Fast defrosting. Use the unique JetDefrost 3D system to defrost food effectively and with ease in your microwave oven.



### Forced Air

Seal in the taste. Thanks to the Forced Air technology, preheated air is circulated inside your microwave oven using an innovative convection system, giving you moist, juicy cooking results.



### 6th Sense Live App

Intuitive assistance from the 6thSenseLive App gives consumers step-by-step instructions, transforming routine recipes into microwaved masterpieces. It learns user preferences, and then suggests recipes and helpful hints to ensure every dish is cooked to perfection.



### Jet Start

Outstanding reheating speed. The JetStart function boosts the heat inside the oven to the maximum for 30 seconds, providing the ideal temperature to reheat food with high water content such as clear soups or beverages.



### 6TH SENSE technology W11 Phoenix

No more guesswork. Simply pick your recipes, and let 6th SENSE cook them to perfection, every time. Up to 160 cooking combinations organized to fit your lifestyle and diet, for a full assisted cooking experience.



### Steam

Healthy, steamed meals, anytime. Steam technology provides the healthiest, tastiest recipes, at the touch of a button.

# W11I MW161

12NC: 859991539470

GTIN (EAN) code: 8003437395918

**Whirlpool**

SENSING THE DIFFERENCE

## MAIN FEATURES

Product group	Microwave
Commercial code	W11I MW161
Main colour of product	Dark grey
Type of micro-wave oven	MW-Combi
Construction type	Built-in
Type of control	Electronic
Type of control settings	LCD
Additional cooking method Grill	Yes
Crisp	Yes
Steam	Yes
Additional cooking method Fan cooking	Yes
Clock	Yes
Automatic programmes	Yes
Height of the product	455
Width of the product	595
Depth of the product	560
Minimum niche height	450
Minimum niche width	556
Niche depth	550
Net weight (kg)	29.7
Cavity capacity (l)	40
Turntable	Yes
Turntable diameter (mm)	400
Integrated Cleaning system	No

## TECHNICAL FEATURES

Current (A)	16
Voltage (V)	230
Frequency (Hz)	50
Length of Electrical Supply Cord (cm)	135
Plug type	Schuko
Timer	Yes
Grill power (W)	1600
Type of grill	N/A
Cavity material	Stainless steel
Interior light	Yes
Additional cooking method Grill	Yes
Position of interior lights of the cavity	Right side
Maximum Air flow -	0
Minimum air flow -	0
Sound power at max. speed (2010/30/EU) -	0
Sound power at min. speed (2010/30/EU) -	0

## PERFORMANCES

6th Sense / Dynamic Intelligence	6th Sense
Number of power levels	7
Maximum micro-wave power (W)	900
Bread defrost	Yes
Jet defrost	Yes
Jet start	Yes
Energy efficiency class - NEW (2010/30/EU) -	-