

WMF250G

12NC: 859991591330

GTIN (EAN) code: 8003437605918

Whirlpool

SENSING THE DIFFERENCE

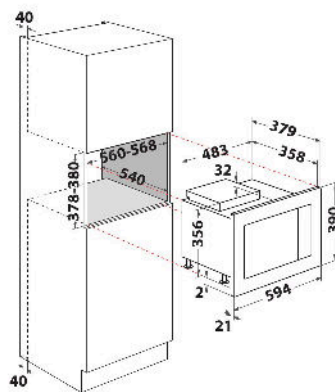

- Cavity 25 L
- Jet Start: rapid food reheating
- Jet Defrost: fast reheating
- Keep warm
- Rising Function
- 900 W microwave
- Maximum dish diameter: 284 mm
- Side opening
- 2 Cooking Methods: Microwave, Grill
- Easy to Clean Technology
- Automatic programs
- Connection Rating: 1400 W
- Quartz Grill
- 1000 W Grill Power
- Inox Finishing
- Child lock
- 7 Power levels

Whirlpool built in microwave oven: inox color - WMF250G

This Whirlpool built in Microwave Oven features: grill function. Jet Defrost function for exceptionally fast and even defrosting.



Grill

Fast grilling, faster cleaning. Your Microwave's powerful grilling function provides the same delicious results as a traditional oven. The tilting motion of the grill also ensures easier cleaning.



JetDefrost

Fast defrosting. Use the unique JetDefrost 3D system to defrost food effectively and with ease in your microwave oven.



DoughRising

Perfect yeast preparation for bread and dough with DoughRising Function. A special program to keep the Maxi Chef's internal temperature stable at 30°: ideal for dough to rise.



Jet Start

Outstanding reheating speed. The JetStart function boosts the heat inside the oven to the maximum for 30 seconds, providing the ideal temperature to reheat food with high water content such as clear soups or beverages.



Quartz grill

Ideal cooking experience. The Quartz Grill reheats and cooks your food faster than a traditional infrared grill. It is resource-efficient, reducing your energy costs, and entirely self-cleaning.



Child lock

Safety first. This Whirlpool Microwave features a child lock system, to prevent toddlers and children from accidentally using this appliance.



Yogurt Function

Make your snacks healthier with YOGURT Function. A dedicated feature to easily ferment yogurts and increase the nutritional properties.



Jet grill

Effortless grilling. The JetGrill program ensures you can enjoy delicious grilled dishes in no time.



Warm keeping

Warm comfort. The Warm Keeping function in this Whirlpool Microwave ensures your food will stay warm for up to 4 hours, while protecting it from drying out, so you can enjoy your meal whenever you like.

WMF250G

12NC: 859991591330

GTIN (EAN) code: 8003437605918

Whirlpool

SENSING THE DIFFERENCE

MAIN FEATURES

Product group	Microwave
Commercial code	WMF250G
Main colour of product	Inox
Type of micro-wave oven	MW+Grill function
Construction type	Built-in
Type of control	Electronic
Type of control settings	Digit
Additional cooking method Grill	Yes
Crisp	No
Steam	No
Additional cooking method Fan cooking	No
Clock	Yes
Automatic programmes	Yes
Height of the product	390
Width of the product	594
Depth of the product	379
Minimum niche height	378
Minimum niche width	560
Niche depth	540
Net weight (kg)	15.95
Cavity capacity (l)	25
Turntable	Yes
Turntable diameter (mm)	284
Integrated Cleaning system	No

TECHNICAL FEATURES

Current (A)	12
Voltage (V)	230-240
Frequency (Hz)	50
Length of Electrical Supply Cord (cm)	135
Plug type	Schuko
Timer	Yes
Grill power (W)	1000
Type of grill	Quartz
Cavity material	Stainless steel
Interior light	Yes
Additional cooking method Grill	Yes
Position of interior lights of the cavity	Right side
Maximum Air flow -	0
Minimum air flow -	0
Sound power at max. speed (2010/30/EU) -	0
Sound power at min. speed (2010/30/EU) -	0

PERFORMANCES

6th Sense / Dynamic Intelligence	No
Number of power levels	7
Maximum micro-wave power (W)	900
Bread defrost	No
Jet defrost	Yes
Jet start	Yes
Energy efficiency class - NEW (2010/30/EU) -	-